

Installation and operating instructions

PROFESSIONAL GAS FULL-PLATE COOKER

**TP-74G TP2-78GP TP4-712GP TPF2-78GP TPF2-78GPE TPF4-712GPV
TPF4-712GPEV TPF4-712GP TPF4-712GPE TPT-74G TP2T-78GP
TP4T-712GP TPFV2-78GPE TPFV4-712GPEV**

Model LIBR.ISTR.TP70G MOD.40

Code 563007202

Review 1

Edition date 27/11/2018

Language English

LOTUS S.p.A.

Via Calmaor, 46

31020 San Vendemiano

+39 0438 778020

+39 0438 778277

Contents

1	INTRODUCTION	3
1.1	Installation drawing	3
1.2	Components.....	4
1.3	Example installation of the appliance.....	12
2	GENERAL INFORMATION.....	13
2.1	Declaration of compliance.....	13
2.2	User information, RAEE Directive on waste electrical and electronic equipment	14
2.3	Technical data table	15
3	INSTALLATION.....	17
3.1	Delivery checks	17
3.2	Removing the packaging	17
3.3	Mechanical installation	17
3.4	Electrical/gas connections	17
4	BURNERS TECHNICAL DATA TABLE (ITGB).....	22
4.1	Burners technical data table	22
5	INSTRUCTIONS FOR USE.....	23
5.1	General information	23
5.2	Lighting and adjusting the open rings.....	23
5.3	Starting the main burner and adjusting the temperature.....	23
5.4	Switching the main burner off	24
5.5	Turning the appliance off.....	24
5.6	Lighting and regulating gas oven burner.....	24
5.7	Turning on and adjusting the static oven	24
5.8	Turning on and adjusting the fan oven.....	25
5.9	Cooking table for the fan oven	26
6	MAINTENANCE.....	28
6.1	Routine.....	28
6.2	Changing the open ring nozzles (fig. C).....	28
6.3	Substituting the nozzle in the pilot burner (fig. D).....	28
6.4	Substituting the nozzle in the oven burner	29
6.5	Minimum setting	29
6.6	Spare parts	29
7	CLEANING.....	31
7.1	Routine cleaning.....	31

1 INTRODUCTION

1.1 Installation drawing

FIG. 1 TP..-7..G

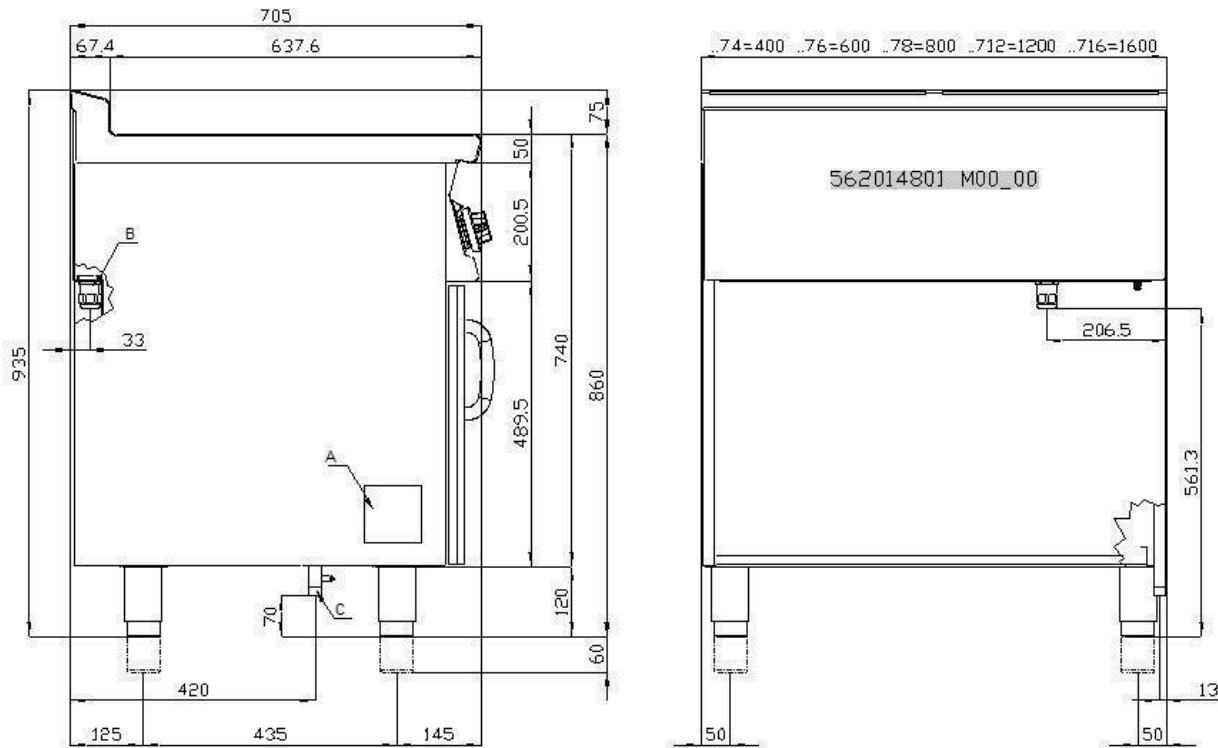

- A Data Plate
- B Electrical connection
- C Gas connection

FIG. 2 TP...T

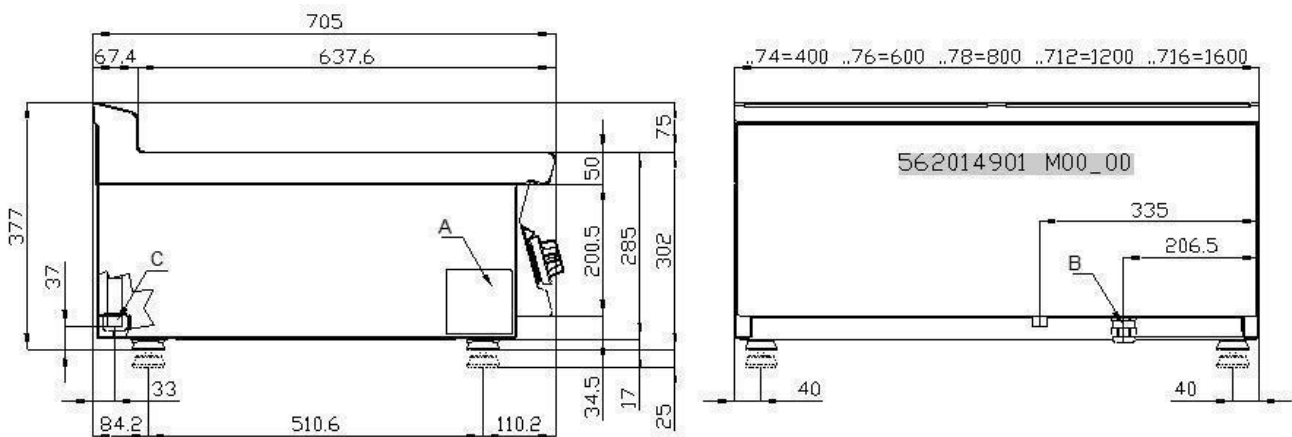

- A Data Plate
- C Gas connection

1.2 Components

FIG. H

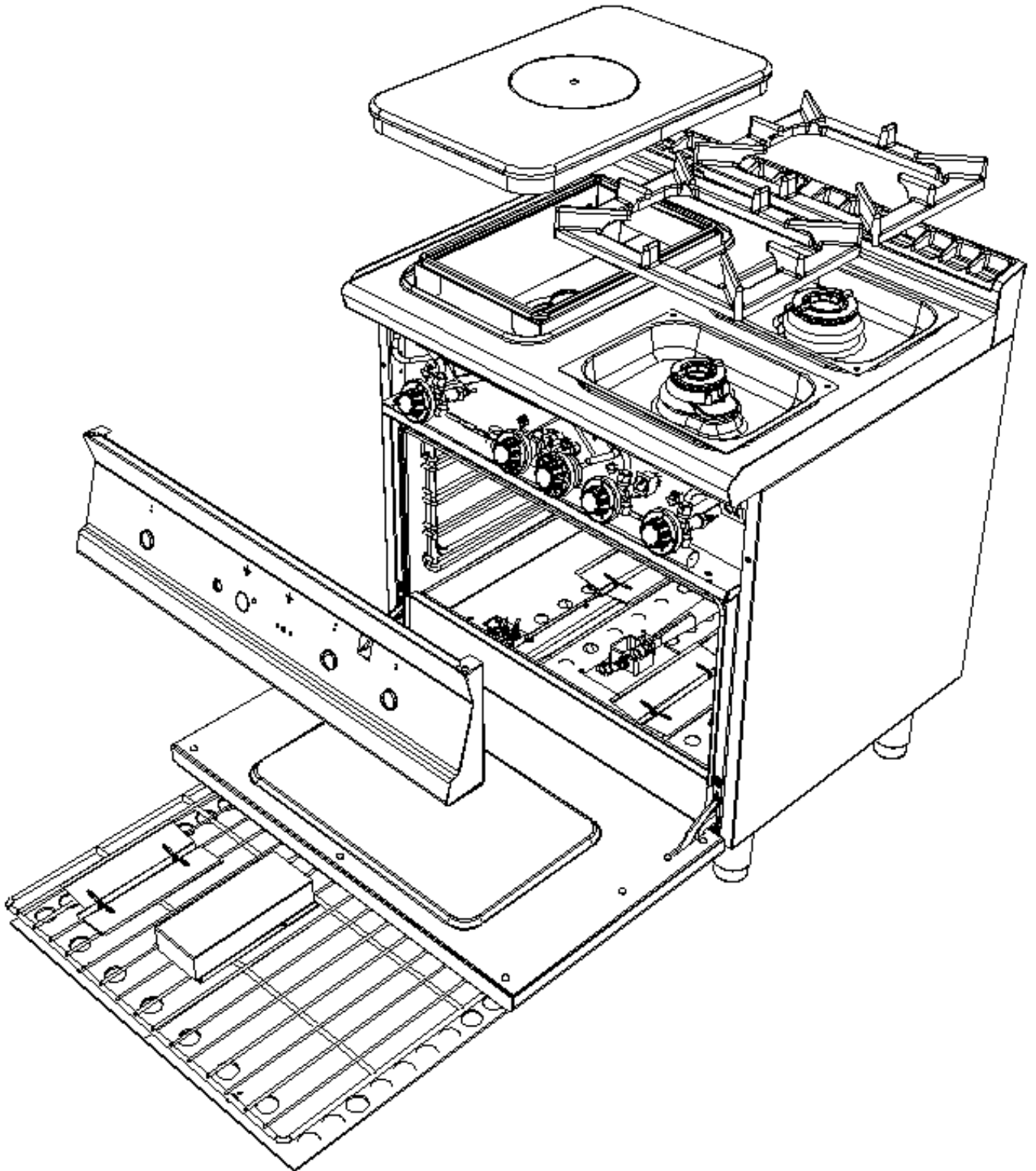
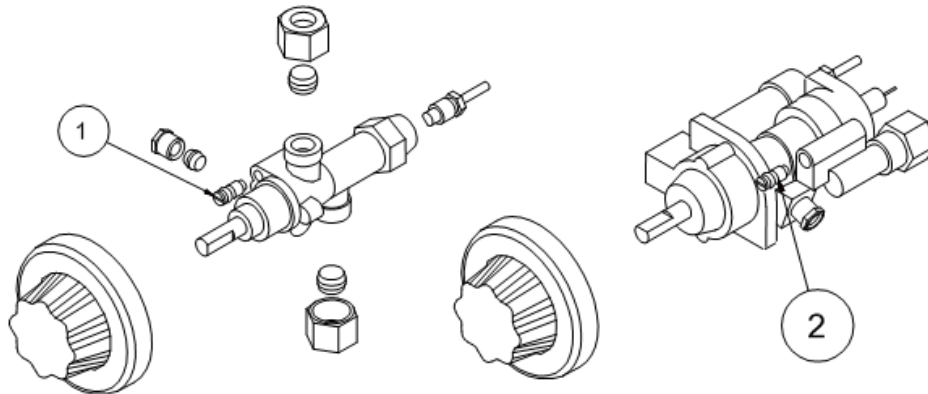
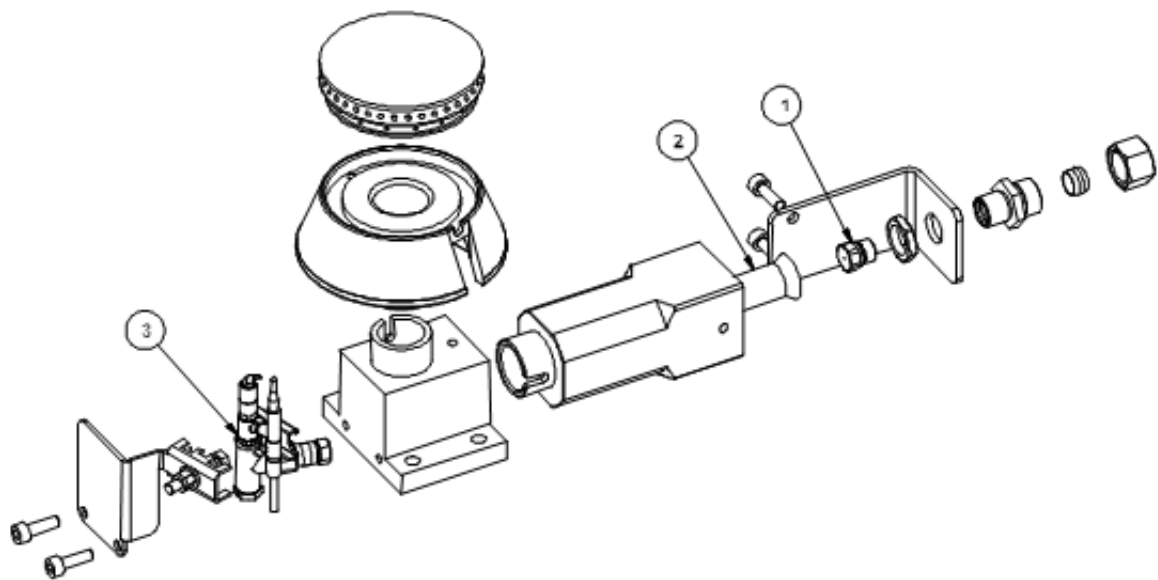

FIG. B



- 1 Flame open by-pass
- 2 Oven by-pass

FIG.C (FLAMES)



- 1 Flame injector
- 2 Air adjustment
- 3 Pilot

FIG. D (Fire pilot)

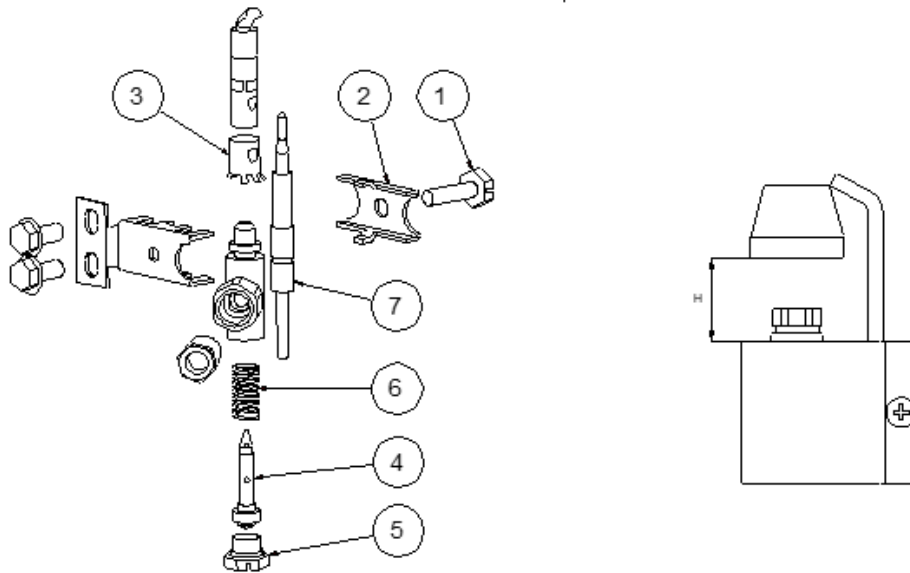

- 1 Pilot bracket screw
- 2 Pilot bracket
- 3 Pilot air bushing
- 4 Pilot injector
- 5 Injector screw
- 6 Spring
- 7 Extends drainage

FIG. E

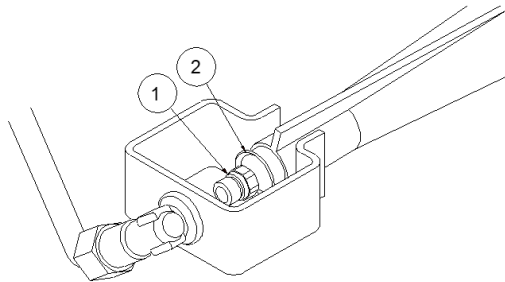

- 1 Oven injector
- 2 Oven air regulation

FIG. F (Oven pilot)

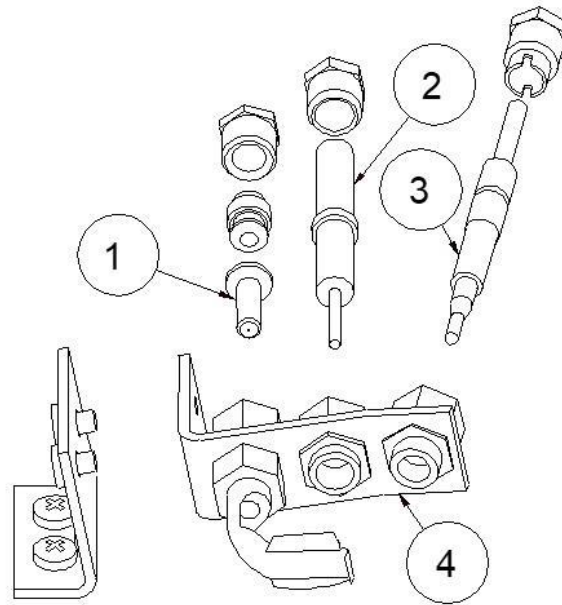

- 1 Pilot light nozzle
- 2 Ignition spark plug
- 3 Extends drainage
- 4 Pilot bracket

FIG. G

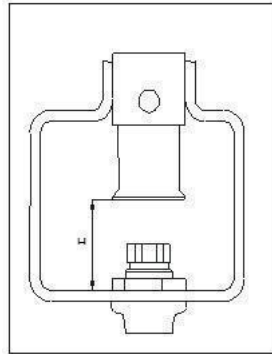

Burner air adjustment

FIG. I

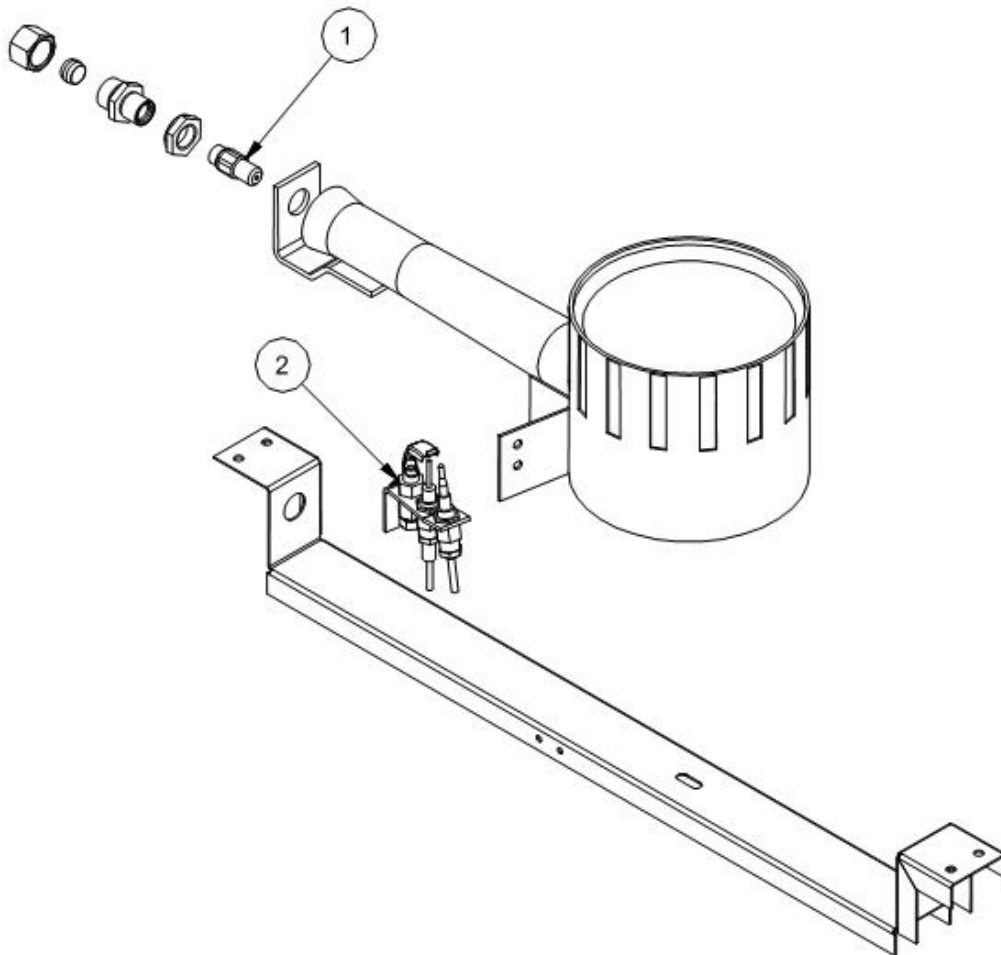

1 Injector
2 Pilot

WIRING DIAGRAM OVEN GN 2/1

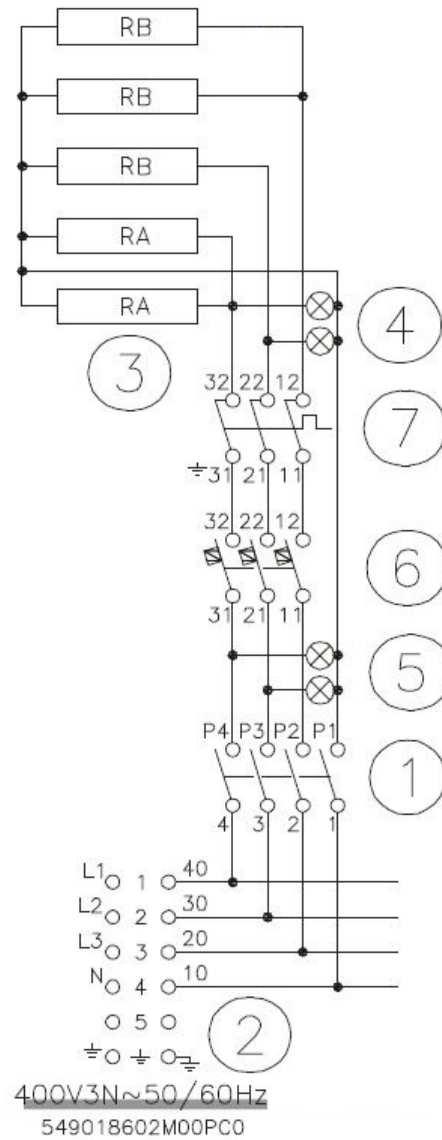

- 1 Switch
- 2 Power supply terminal board
- 3 Heating element
- 4 White indicator light
- 5 Green indicator light
- 6 Thermostat
- 7 Safety thermostat

WIRING DIAGRAM OVEN GN 3/1

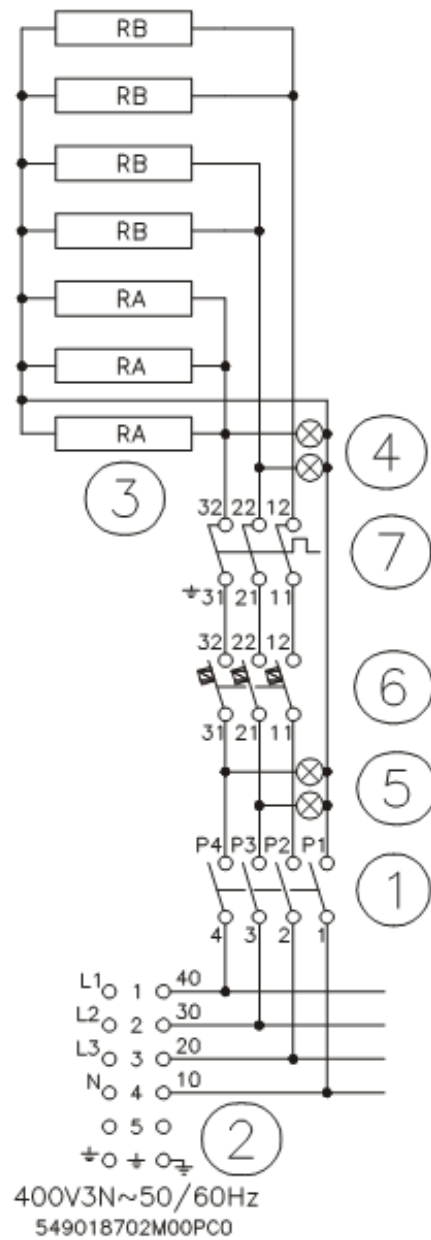

- 1 Switch
- 2 Power supply terminal board
- 3 Heating element
- 4 White indicator light
- 5 Green indicator light
- 6 Thermostat
- 7 Safety thermostat

VENTILATED ELECTRICAL OVEN

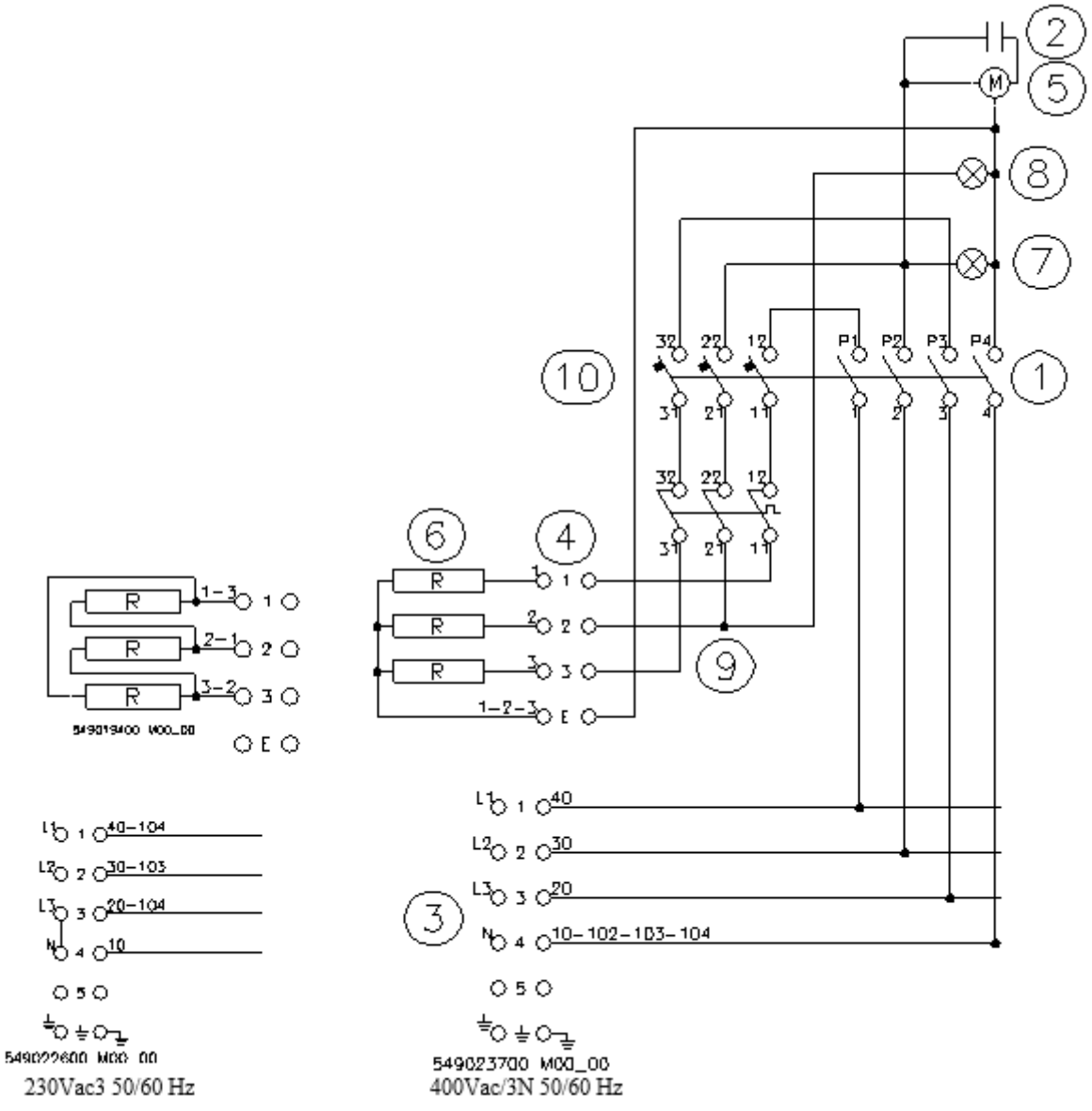

- 1 Switch
- 2 Condenser
- 3 Power supply terminal board
- 4 Switching terminal board
- 5 Motor
- 6 Heating element
- 7 White indicator light
- 8 Green indicator light
- 9 Safety thermostat
- 10 Thermostat

1.3 Example installation of the appliance

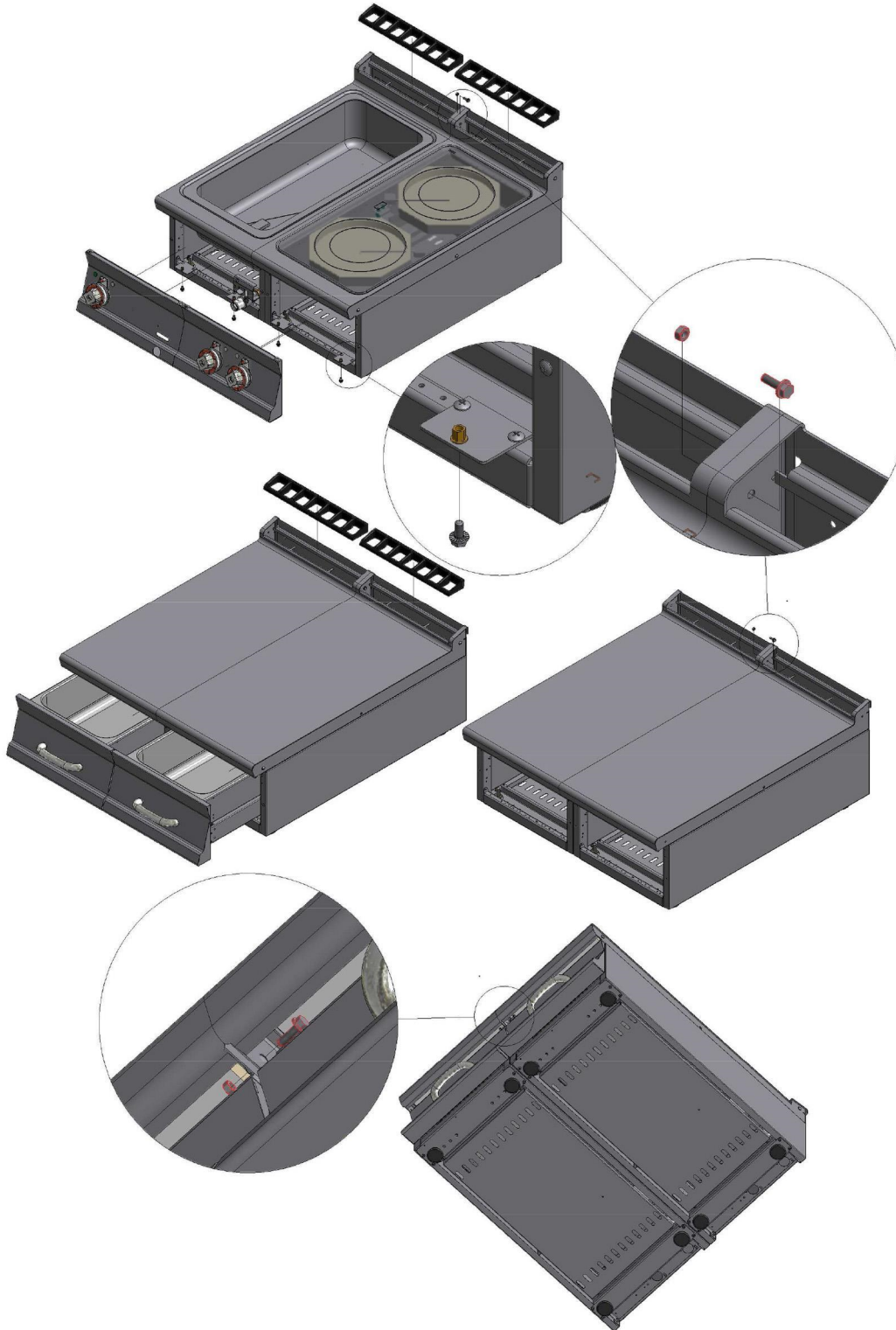

562026000M00P00.idw 1 di 1

2 GENERAL INFORMATION

2.1 Declaration of compliance

The manufacturer declares that the appliances comply with the requirements of the regulation GAR 2016/426 for the gas part and directive 2014/30/EU, 2014/35/EU for the electrical part. Installation must be performed in compliance with current regulations, especially with regard to ventilation of the premises and the exhaust gas evacuation system.

- Read the warnings in this manual carefully. They provide important information about safe installation, use and maintenance.
- The instruction manual must be kept for the entire duration of the equipment and made available to users for every possible consultation. The manual should be consulted for any information concerning installation, use and maintenance of the appliance.
- After removing the packaging, check the integrity of the equipment.
- All packaging materials (plastic bags, polystyrene, staples, etc.) must be disposed of in compliance with current regulations.
- Before connecting the appliance, make sure that the information on the data plate matches the electricity and gas mains where the appliance is installed. **The manufacturer accepts no liability if the equipment is not connected in accordance with current regulations.**
- Always keep all parts of the equipment clean to avoid the risk of oxidation/rust and/or aggression by chemical agents.
- The equipment must only be used by personnel trained for the purpose.
- **The installation must be implemented by professionally qualified personnel in accordance with the manufacturer's instructions and current reference standards.**
- The electrical safety of this equipment is only ensured when it is correctly connected to an effective ground/earth system as required by current electrical safety standards. The manufacturer cannot be held liable for any damage caused if the system is not connected to ground/earth.
- Before carrying out any cleaning or maintenance tasks on the equipment, unplug it from the electricity mains. In the event of faults or malfunctions, always deactivate the appliance.
- **Repair work of any kind must only be performed by qualified personnel.**
- This appliance must only be used for its expressly intended purpose for cooking or heating food. Any other use is considered improper.
- The appliance is intended for professional use and must be used by trained personnel.
- The installation and possible transformation to another power supply voltage (if envisaged), or transformation for operation with another type of gas, must be implemented exclusively by qualified and authorised professional personnel.
- Before using the appliance, carefully clean all surfaces intended to come into contact with food.
- The manufacturer declines any and all liability for any direct or indirect damage resulting from improper use of the equipment. The manufacturer declines any and all liability for damage caused by incorrect installation, tampering, poor maintenance and unskilled use. Moreover, the manufacturer declines any liability for possible inaccuracies that may be contained in this booklet attributable to errors in transcription or printing and equally reserves the right to make any changes to the product it deems useful and/or necessary without compromising its essential characteristics.
- **The manufacturer cannot be held liable for any damage caused by failure to comply with these basic standards and all other use and maintenance standards contained in this booklet.**

2.2 User information, RAEE Directive on waste electrical and electronic equipment

With regard to the regulatory framework of reference of the European Community, we remind the user of the following:

- Used AAE (Electrical and Electronic Equipment) products must be collected separately
- The user can carry out this collection in the RAEE collection systems and return the equipment to the distributor when purchasing a new one
- Plus being RoHS compatible, (in accordance with Directive 2011/65/EU on the restriction of the use of certain hazardous substances in electrical and electronic equipment) the potential effects on the environment and human health may be due to the misuse of the same equipment or parts of it
- The symbol  next to the rating plate indicates the obligation of separate collection
- The penalties provided for in the event of improper disposal of RAEE (Waste Electrical and Electronic Equipment) are those provided for by the national transpositions of European Directives 2012/19/EU

2.3 Technical data table

Electrical technical data table TPF S70GE

MODEL	DIMENSION S	POWER SUPPLY	MAXIMUM ABSORPTION (A)	MAXIMUM ELECTRICAL POWER (kW)	Emissivity dB (A)	POWER SUPPLY CABLE silicon type
TPF2-78GPE	80x70x29h	400V~3N 50/60 Hz	10,4	5	/	5 x 1,5 mm ²
TPF4-712GPEV	120x70x90h	400V~3N 50/60 Hz	10,4	5	/	5 x 1,5 mm ²
TPF4-712GPE	120x70x90h	400V~3N 50/60 Hz	10,4	6,9	/	5 x 1,5 mm ²
TPFV2-78GPE	80x70x29h	400V~3N 50/60 Hz	8,06	5,32	<70	5 x 1,5 mm ²
TPFV2-78GPE	80x70x29h	230V~3 50/60 Hz	13,35	5,32	<70	4 x 1,5 mm ²
TPFV4-712GPEV	120x70x90h	400V~3N 50/60 Hz	8,06	5,32	<70	5 x 1,5 mm ²
TPFV4-712GPEV	120x70x90h	230V~3 50/60 Hz	13,35	5,32	<70	4 x 1,5 mm ²

Technical data table TPF S70GE

MODEL	DIMENSION S	BURNER	BURNER	BURNER	BURNER	BURNER	BURNER	POWER.	FITTING	FUME DISCHARGE
		TP 7 kW	FLAMES 7.5 kW	FLAMES 5.5 kW	FLAMES 3.5 kW	OVEN 7.3 kW	OVEN 11 kW	TOT (kW)	GAS ISO 7-1	TYPE
TP-74G	40x70x90h	1	/	/	/	/	/	7	R1/2GM	A
TP2-78GP	80x70x90h	1	1	1	/	/	/	20	R1/2GM 3/4GM(1007)	A
TPF2-78GP	80x70x90h	1	1	1	/	1	/	27,3	R3/4GM	B11
TPF2-78GPE	80x70x90h	1	1	1	/	/	/	20	R1/2GM 3/4GM(1007)	A
TPFV2-78GPE	80x70x90h	1	1	1	/	/	/	20	R3/4GM	A
TP4-712GP	120x70x90h	1	1	2	1	/	/	29	R3/4GM	A
TPF4-712GPV	120x70x90h	1	1	2	1	1	/	36,3	R3/4GM	B11
TPF4-712GP	120x70x90h	1	1	2	1	/	1	40	R3/4GM	B11
TPF4-712GPEV	120x70x90h	1	1	2	1	/	/	29	R3/4GM	A
TPFV4-712GPEV	120x70x90h	1	1	2	1	/	/	29	R3/4GM	A
TPF4-712GPE	120x70x90h	1	1	2	1	/	/	29	R3/4GM	A
TPT-74G	40x70x29h	1	/	/	/	/	/	7	R1/2GM	A
TP2T-78GP	80x70x29h	1	1	1	/	/	/	20	R1/2GM	A
TP4T-712GP	120x70x29h	1	1	2	1	/	/	29	R3/4GM	A

DESIGN ASSEMBLY/TRANSFORMATION ELECTRICAL LINKING TERMINAL BLOCK PERNIONS (see technical data table)

• **POWER SUPPLY CONNECTION**

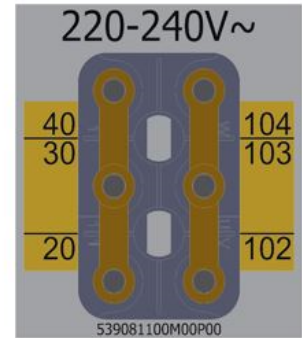
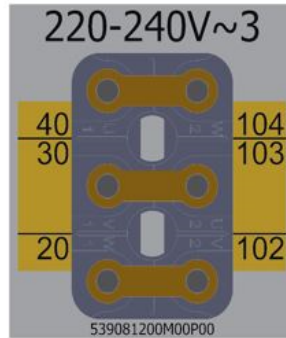
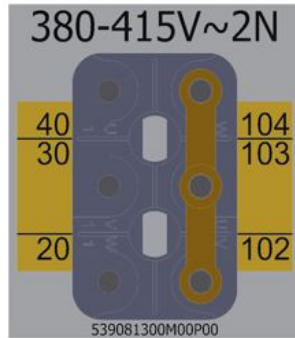
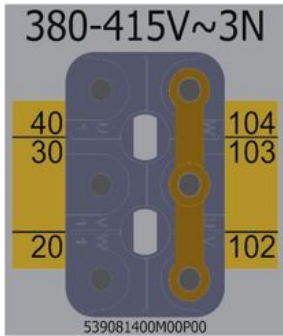

• **HEATING ELEMENT CONNECTION**

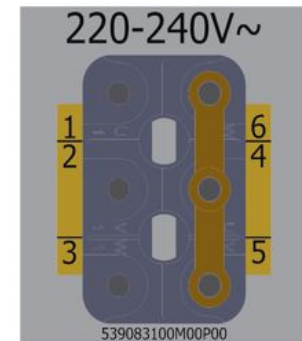
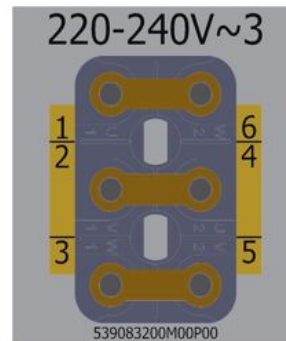
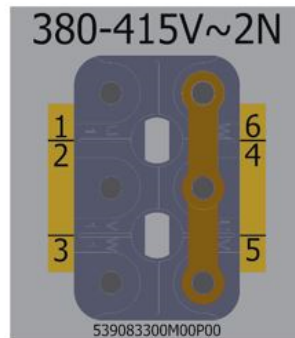
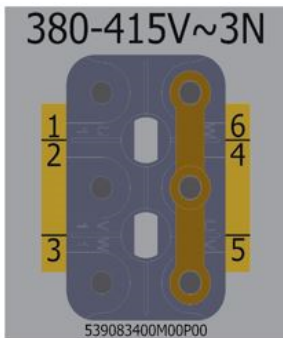

3 INSTALLATION

3.1 Delivery checks

On delivery, it is important to check the following:

- External conditions of the packaging
- The general status of the equipment
- The conformity of the model with the information in the technical data plate and the instruction manual
- The conformity of the equipment and components to the order form

3.2 Removing the packaging

While removing the packaging, take care not to damage the appliance. Remove the protective film from the stainless steel and eliminate any traces of glue. Do not smoke. Perform this operation away from sources of heat and wear protective gloves. Do not disperse packaging material in the environment, keep it out of the reach of children and dispose in compliance with current legislation.

3.3 Mechanical installation

Place the appliance on a flat base. Adjust and stabilise the appliance by acting on the support feet. Make sure that the surrounding walls and/or equipment are capable of withstanding the heat emitted by this appliance. Connect the water supply (if necessary).



Caution

Do not install the appliance near equipment/machines used in cold processes. If the appliance has to be installed close to cold process equipment, it is advisable to install non-combustible thermal insulating material and/or neutral elements between them.

3.4 Electrical/gas connections

Before being offered for sale on the market, the appliance was subjected to gas and electrical testing (as required). The appliance is supplied without a power cable. The installation technician must connect the equipment in compliance with current safety regulations on the basis of the power of the appliance.



Note

The ID plate is located in the compartment inside the door for appliances with compartments, or on the left side for appliances with an oven or a top. A second plate with the model and serial number is located inside the dashboard and a third is included with the certificate of conformity. The serial number can also be tracked from the sales document (after 2008). The plate has all the data needed for correct electrical installation. The installation and possible conversion to another power supply voltage (if envisaged) must be implemented exclusively by professionally qualified and authorized personnel. Before using the appliance, carefully clean all surfaces intended to come into contact with food.

Warning

Installation operations, any conversion to other types of gas and start-up must only be performed by qualified personnel, in accordance with current regulations.

Gas systems, electrical connections and premises where the appliances are installed must comply with current regulations in the country of installation; in particular, the appliance must be installed in a room with good ventilation, if possible under a suction hood to ensure complete evacuation of the exhaust gases formed during combustion. The air required for combustion is 2 m³/h per kW of installed power. The appliance can be installed alone or in series with other appliances in our production range. A minimum distance of 10 cm between appliances must be respected to prevent contact with any walls made of flammable material; furthermore, appropriate measures should also be adopted to ensure the thermal insulation of flammable parts, such as the installation of heat shields; take special care to ensure that appliances are installed in an appropriate and safe manner. The support feet can be adjustable in height and any unevenness can therefore be eliminated.

ELECTRICAL CONNECTION

Caution

In accordance with international provisions, when connecting the appliance an automatic device must be installed up-line of it so that the device can be fully disconnected from the mains; this device must have a contact aperture of at least 3 mm.

The connection terminal is located behind the rear wall. Proceed as follows to install the power supply cable:

- Remove the rear panel.
- Pass the new connection cable through the cable gland, connect the leads to the corresponding terminal on the terminal block and fasten them securely.
- Lock the cable with the cable gland and refit the panel. The earth/ground lead must be longer than the others so that if the cable gland breaks it is disconnected after the power cables.

Note

Make sure that the mains voltage complies with the data on the appliance's ID plate and that there is good conductivity to earth/ground. Pay attention when inserting leads to ensure they do not obstruct the normal course of work and routine appliance cleaning operations. Also make sure that the power cable is never pulled taut and is not placed in contact with sources of heat.

Note

The connection cable must have the following characteristics: it must be silicone type (to withstand temperatures of 180 °C), and must have an appropriate cross-section for the power of the appliance (see technical data table).

EQUIPOTENTIAL

The appliance must be connected to an equipotential system. The connecting screw is located on the rear of the appliance and is marked by the yellow symbol above it.

Warning

The manufacturer is not liable for and does not indemnify damages caused by incorrect inadequate installations that do not comply with these instructions.

GAS CONNECTION

The gas connection (see installation drawing) must be implemented using steel or copper pipes or steel hoses, in compliance with applicable national standards. All appliances must be equipped with a gas shut-off

valve and fast-closing valve. Once installation is complete, make sure that there are no gas leaks from the fittings; to do this, do not use a naked flame but substances that do not cause corrosion, such as solutions of soapy water or leak detectors. All our appliances are subjected to detailed examination: the type of gas, pressure in use and the pertinent category are indicated on the data plate (see attachment).

**Note**

The year of construction of the appliance is indicated under "N" on the data plate. The first 2 digits indicate the year of construction.

• THERMAL OUTPUT CONTROL

The appliances must be checked in order to verify that their thermal output is correct:

- Thermal output is indicated on the appliance's data plate;
- Firstly, make sure that appliance is set for the type of gas used and then make sure that the indication on the data plate matches this gas. To adapt the appliance to another type of gas, make sure that the type of gas in question complies with the information in this instruction manual.

**Warning**

Pressure is measured with a pressure gauge (minimum resolution of 0.1 mbar) mounted on the appropriate socket. Remove the M6 locking screw and insert the pressure gauge tube. The test must be performed with all the burners on the appliance switched on and all the appliances in the same line switched on. After taking the measurement, replace the screw, firmly tighten and check the seal.

Liquid gas connection G30 / G31

The liquid gas connection pressure is 30 mbar for butane and 37 mbar for propane. Check the data plate, measure the pressure and verify that the description of the nozzle installed matches the information provided by the manufacturer.

Methane gas connection H G20

The methane gas connection pressure is 20 mbar. Check the data plate, measure the pressure and verify that the description of the nozzle installed matches the information provided by the manufacturer.

• CHECKING THE PRIMARY AIR FOR MAIN BURNERS AND PILOT NOZZLE

For burners equipped with air adjustment, set the adjustable bushing and lock it with a screw. The "Burner technical data" table shows approximate values for the "h" parameter (primary air). The primary air flow volume must be adjusted to avoid a flame cut-off when the burner is cold and a flame blowback when the burner is hot. The pilot air adjustment is set testing for the gas which the appliance will use. In the event of conversion to other types of gas, adjust the air using the adjustment bush until the pilot flame is steady and has an intense blue colour.

Disposition for conversion and installation for other types of gas:

Our appliances are tested and set for liquid gas or natural gas (see attached data plate). Conversion or adaptation to another type of gas must be performed by a specialist technician. The nozzles for the various types of gas are contained in a bag included in the supply and are marked in hundredths of mm (see "Burners" technical data table).

• INSTRUCTIONS FOR EVACUATING EXHAUST GASES

- "A" type devices (see data plate)

"A" type appliances must discharge combustion products into appropriate hoods, or similar devices, connected to an efficient fume stack or directly to the outside. (Natural evacuation) Fig. 1

If this is not possible, using an air suction device connected directly to the outside is permitted (**Forced Evacuation**) Fig.2, having a flow capacity not lower than the value defined in point 4.3 of the UNI-CIG 8723 standard.

- In the case of forced evacuation

The gas supply to the appliance must be directly servo-controlled by the system and must stop if the flow rate drops below the values indicated in point 4.3 of the UNI-CIG 8723 standard. Resetting the gas supply to the appliance must be possible only by hand.

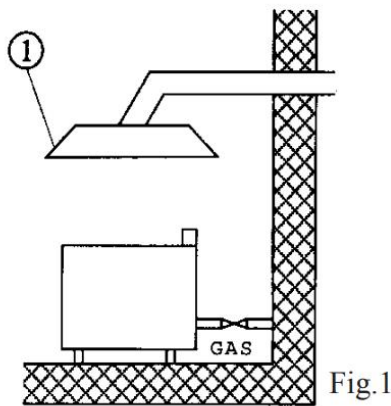

Fig.1

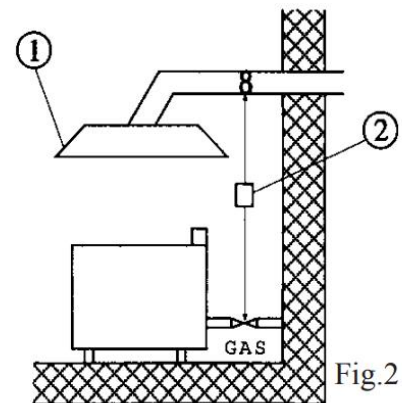

Fig.2

- 1 Extractor hood
- 2 Servo system

- "B11" type devices (See data plate)

Natural evacuation (fig.3)

Connection to an efficient natural draft fume stack by means of a windproof connection, with discharge of combustion products directly to the outside

Forced evacuation (fig.4)

The gas supply to the appliance must be directly servo-controlled by the forced evacuation system and must stop if the flow rate drops below the values indicated in point 4.3 of the UNI-CIG 8723 standard. Resetting the gas supply to the appliance must be possible only by hand. If the installation is under a hood, the terminal part of the appliance's exhaust pipe must be at least 1.8 meters from the appliance's support surface (ground). The outlet section of the exhaust pipes for combustion products must be placed within the perimeter in relation to the hood itself.

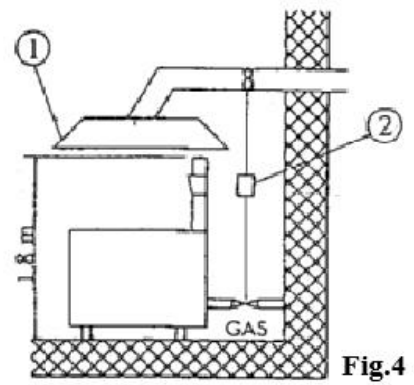
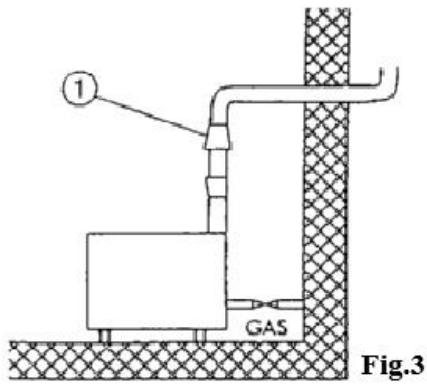

- 1 Windproof fume stack (fig.3) - Extractor hood (fig.4)
- 2 Servo system

"B11" type appliances are supplied on request with a hood or a hood and windproof fume stack to be assembled and delivered separately.

4 BURNERS TECHNICAL DATA TABLE (ITGB)

4.1 Burners technical data table

Technical data table - Burners TP S70G

	12.68 kWh/KG G30 BUTANE 30 mbar	12.87 kWh/KG G31 PROPANE 37 mbar	9.45 kWh/m3st. G20 METHANE H 20 mbar
Burner TP max 7 kW-min 4 kW			
Burner injector 1/100 mm	130A	130A	195
Minimum adjustment 1/100 mm	100	100	adjustable
Pilot injector 1/100 mm	19	19	27
Consumption	kg/h 0.552	kg/h 0.544	m3 st./h 0.740
Burner max 3.5 kW-min 1.15 kW			
Burner injector 1/100 mm	90	90	145
Minimum adjustment 1/100 mm	50	50	adjustable
Pilot injector 1/100 mm	20	20	35
Consumption	kg/h 0.276	kg/h 0.272	m3 st./h 0.370
Primary air h = mm	open	open	open
Burner max 5.5 kW-min 1.55 kW			
Burner injector 1/100 mm	115	115	175
Minimum adjustment 1/100 mm	60	60	adjustable
Pilot injector 1/100 mm	20	20	35
Consumption	kg/h 0.434	kg/h 0.427	m3 st./h 0.582
Primary air h = mm	open	open	20
Burner max 7.5 kW-min 2.5 kW			
Burner injector 1/100 mm	135	135	205
Minimum adjustment 1/100 mm	75	75	adjustable
Pilot injector 1/100 mm	20	20	35
Consumption	kg/h 0.591	kg/h 0.582	m3 st./h 0.794
Primary air h = mm	open	open	20
Oven burner max 7.3 kW-min 2.2 kW			
Burner injector 1/100 mm	145	145	205
Minimum adjustment 1/100 mm	75	75	adjustable
Pilot injector 1/100 mm	1x19	1x19	1x27
Consumption	kg/h 0.576	kg/h 0.567	m3 st./h 0.772
Primary air h = mm	12	12	12
Oven burner max 11 kW-min 3.5 kW			
Burner injector 1/100 mm	175	175	270
Minimum adjustment 1/100 mm	100	100	adjustable
Pilot injector 1/100 mm	1x19	1x19	1x27
Consumption	kg/h 0.867	kg/h 0.855	m3 st./h 1.164
Primary air h = mm	13	13	13

5 INSTRUCTIONS FOR USE

5.1 General information

This appliance must only be used for its expressly intended purpose for cooking or heating food. Any other use is considered improper. The appliance is also intended for industrial use and **must only be used by personnel trained for use and aware of the risks that the hot element entails.**





Warning

The appliance operates at high temperatures, so the following is necessary:

- *Pay attention to the areas surrounding the hot surface during routine normal operation (danger of scalding);*
- ***RISK OF BURNS*** *Do not touch hot surfaces floor with your hands or other parts of the body to avoid burns caused by high temperatures;*
- *After switching off the appliance, wait for a sufficient time for it to cool before carrying out any cleaning or maintenance operation.*

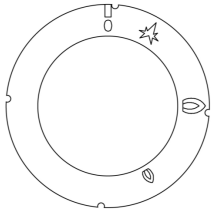
5.2 Lighting and adjusting the open rings



The corresponding burner marked on the index is indicated above each knob on the front panel 



- Place gas knob in position  and hold it pressed for a few seconds. Simultaneously, move an igniter close to the pilot to ignite it



Note

The flame might go out, in which case the procedure must be repeated.

5.3 Starting the main burner and adjusting the temperature

- Turn the knob into position  to set the burner to maximum
- Turn the knob into position  to set the burner to minimum

5.4 Switching the main burner off

- Turn the knob into position ★ . The burner turns OFF and only the pilot flame remains ON

5.5 Turning the appliance off

- Press and turn the gas cock knob to position "0". This control blocks the gas supply to both the main burner and the pilot burner

5.6 Lighting and regulating gas oven burner

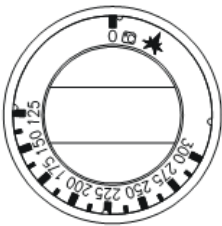

To switch ON, turn the knob to the left from the "0" position into the ★ position; hold the knob pressed and activate the button with the ⚡ symbol until the pilot lights up

- Ignition of the flame can be checked through the inspection hole on the bottom of the oven



Note

The flame might go out, in which case the procedure must be repeated.

- Set the knob to the desired temperature position
- Turn the knob into position ★ . The burner turns OFF and only the pilot flame remains ON
- Press and turn the gas cock knob to position "0". This control blocks the gas supply to both the main burner and the pilot burner



5.7 Turning on and adjusting the static oven

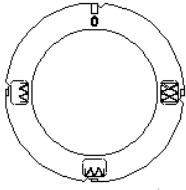

- Turn the control knob to the right and set the desired temperature

- Also turn the knob of the selector, setting one of the three positions



-  Top + bottom heating element
-  Bottom heating element
-  Top heating element

5.8 Turning on and adjusting the fan oven

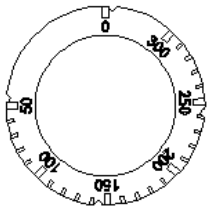

The hot air put in circulation by the fan is distributed in the entire oven chamber, ensuring even cooking. The uniform heating of the chamber makes it possible to cook different foods at the same time on different levels. Turn the knob on the panel from “O” to the desired position between 50° and 300°C, the white and green indicator lights will turn on

- The green indicator light indicates that the appliance is powered
- The white indicator light indicates that the heating element is functioning and when it turns off, this means that the temperature has been reached. Turn the knob to “O” to switch off the appliance

MECHANICAL TIMER



The cookers have an acoustic timer that can signal a maximum time of 120 minutes. Turn the knob to the right, position it to the preselected time, between 0 and 120 minutes (see figure); once the set time has elapsed, the acoustic timer activates



Caution

When the oven is operating, the door must not remain open as it could overheat and damage the knobs and the protective plates

5.9 Cooking table for the fan oven

Ventilated electrical oven cooking table

Type of food	Guide no. from the bottom	Quantity Kg	Temperature °C	Min. cooking time
Sweets				
With a beaten dough, in a mould	1-3	1	175	60
With a beaten dough, without a mould	1-3-4	1	175	50
Shortcrust pastry, cake base	1-3-4	0,5	175	30
Shortcrust pastry with moist filling	1-3	1,5	175	70
Shortcrust pastry with dry filling	1-3-4	1	175	50
With natural leavened pastry	1-3	1	175	50
Small sweets	1-3-4	0,5	160	30
Meat				
<i>Roasts cooked on the grill</i>				
Veal	2	1	180	60
Beef	2	1	180	70
Roast beef	2	1	220	50
Pork	2	1	180	70
Chicken	2	1-1,5	200	70
<i>Roasts cooked in the pan</i>				
Veal	1-3	1	160	90
Beef	1-3	1	160	90
Pork	1-3	1	160	90
Chicken	1-3	1-1,5	180	90
Turkey slices	1-3	1,5	180	120
Duck	1-3	1-1,5	180	120
Stews				
Beef stew	1	1	175	120
Veal stew	1	1	175	110
Fish				
Fillets, steaks, cod, hake, sole	1-3	1	180	30
Mackerel, turbot, salmon	1-3	1	180	45
Oysters	1-3	1	180	20
Baked dishes				
Baked pasta	1-3	2	185	60
Baked vegetables	1-3	2	185	50
Sweet and salty soufflés	1-3	0,75	180	50
Pizzas and calzones	1-3-4	0,5	200	30
Toast	1-3-4	0,5	190	15
Defrosting				
First courses	1-3	1	200	45
Meat	1-3	0,5	50	50
Meat	1-3	0,75	50	70
Meat	1-3	1	50	110



Note

- *The indication of use of the levels shown in the table is recommended when cooking on multiple levels*
- *The indicated times refer to cooking on only one level. Add 5-10' when cooking on multiple levels*
- *Add 20' for beef, veal, pork and turkey roasts with bones or for meat rolls*
- *The cooking times can vary depending on the type of food, their homogeneity and their volume*
- *Before cooking for the first time, select the lower value of the temperature setting range indicated in the table*
- *The cooking time will be extended based on the lower heat*

6 MAINTENANCE

6.1 Routine

When using the appliance over time, it is essential to perform regular maintenance to ensure safe operation. We therefore recommend stipulating a service contract.



Caution

Maintenance must only be performed by specialist personnel in compliance with current regulations and our own instructions.

Before carrying out any maintenance and/or cleaning operation:

- Disconnect the appliance from the mains power supply and/or close the gas.
- Wait for a sufficient time for the appliance to cool down.
- Do not wash the appliance with direct or high-pressure jets of water, since any infiltration of water into the electrical components could jeopardise correct operation of the appliance and its safety systems.



Warning

For maintenance/replacement of components, order and use only original spare parts.

Replacing parts must exclusively be performed by authorised and/or qualified personnel. When replacing the electrical components of the machine and the electrical panels, scrupulously follow the technical characteristics for the replacement component indicated on the component itself. The appliance does not require any special maintenance but during the use of the equipment it is advisable to check the following at least once a year (possibly increasing the frequency depending on the degree of use):

- The status of connections especially on the terminal board and the power supply cable, as well as the status of the gas connections;
- The operating condition of the various components (perform a functional test);
- For appliances fitted with rotary resistances, remove the hub, grease it and replace the three o-ring seals to avoid possible leaks.

6.2 Changing the open ring nozzles (fig. C)

- Remove the grills, burners and pans. Use 12 wrench to replace the nozzles with the appropriate ones and adjust the primary air (h) (see the "burners" technical data table) by unscrewing the locking screw
- After setting the adjustment, lock the screw, set the minimum by turning the screw to the right or left until heat reaches 1.15 kW for the 3.5 kW burner, 1.5kW for the 5.5 kW burner and 2.5 kW for the 7.5 kW burner

6.3 Substituting the nozzle in the pilot burner (fig. D)

- Remove the grills, burners and pans; using an 8 wrench loosen the nozzle holder and an 11 wrench to unscrew the bottom of the nozzle holder, use a slotted screwdriver unscrew the pilot nozzle and replace it with an appropriate one, tightening it fully
- Reassemble everything and adjust the air using the adjusting bushing until the pilot flame is steady and has an intense blue colour

**Warning**

After conversion to another type of gas, update the technical data plate to indicate the type of gas for which the appliance has been converted.

6.4 Substituting the nozzle in the oven burner

- Remove the base of the oven
- Unscrew the screws securing the burner nozzle guard
- Replace the nozzle using a suitable wrench (see the "burners" technical data table)
- Set the air adjustment bush to the corresponding value in the "technical data" table by unscrewing the locking screw complete with locknut, adjust the minimum by turning the screw to the right or left until the heat output is 2.2 kW for the 7.3 kW burner, 3.5 kW for the 11 kW burner. This procedure is only possible after having operated the oven burner for no more than about 20 minutes (knob in pos.300)
- After completing this procedure, refit the burner nozzle guard
- Use an appropriate wrench to replace the pilot nozzle
- After the adjustment, check ignition at maximum and minimum settings. Make sure that the flame, on passing rapidly from maximum to minimum, does not present problems and that it does not go out after closing or opening the oven door quickly

6.5 Minimum setting

- After conversion to use another type of gas, or if a flame is too high when the knob is in position  (small flame), adjust the minimum setting by turning the by-pass screw. For operation with LPG, the by-pass must be completely closed; for operation with natural gas, it must first be closed and then opened by 1/4 turn

6.6 Spare parts

It is possible to replace parts such as the gas tap, thermocouple, spark plug or the gas pipes simply and quickly.

To replace such parts, proceed as follows:

- **GAS TAP:** after disassembling the front panel, unscrew the gas connection screw couplings, remove the coupling, replace the faulty parts and install the new ones in sequence
- **THERMOCOUPLE:** unscrew the pilot burner coupling, unscrew the gas tap coupling in the same way and replace the element
- **SPARK PLUG:** unscrew the coupling, remove the damaged one and replace it.

**Caution****WHAT TO DO IN THE EVENT OF FAULTS:**

Close the gas connection cock and/or switch off the power using the up-line device. Notify customer service.

**Warning**

MEASURES TO BE TAKEN IF THE APPLIANCE IS NOT TO BE USED FOR A LONG TIME:

Close the gas cock and/or disconnect the power supply. Clean the system as specified above.

7 CLEANING

7.1 Routine cleaning

**Caution**

The use of flammable fluids to clean the appliance is forbidden

To ensure hygiene and the durability of the appliance, perform external cleaning on a regular basis, taking care not to damage the cables and the electrical connections. Before starting cleaning, disconnect the appliance from the power supply. Parts in steel can be washed with warm water and a neutral detergent: Rinse them thoroughly to eliminate all traces of detergent and then dry with a dry cloth. Do not use abrasive and corrosive detergents. Enamelled parts must be washed with soapy water. For appliances that included an oven, cleaning it is made easier by removing the support grid. Thorough, daily cleaning prevents faults and accumulated deposits of fat and/or food. The steels used in the manufacture of professional equipment are tried and tested materials of the highest quality. Thanks to their characteristics, they are ideal materials for use with food substances.

Consequently, when using stainless steel appliances, the following suggestions must be observed:

- Stainless steel surfaces must always be kept clean, also ensuring contact with the air. The lack of oxygen under layers of scale, starch, egg white or other deposits means that surfaces can be affected by corrosion
- Do not use products containing salt or sulphuric acid to remove scale. Suitable products are available commercially but a diluted solution of acetic acid can also be used
- To clean STAINLESS STEEL appliances, it is advisable to use detergents specifically formulated for this material. For "minor cleaning", a mild washing up liquid solution may also be used
- **Do not wash the appliance with jets of water under pressure**
- Avoid using detergents containing abrasive powders or bleaches of any kind
- Lockable stainless steel appliances, during periods of inactivity, must be left uncovered so that air can freely access internal metal surfaces
- Stainless steel must not remain in contact for long periods with concentrated acids or with aromatised concentrates such as salt solutions, mustard, spice mixtures or the like. At certain temperatures and concentrations, these substances can damage the passive layer. Contact surfaces must therefore be immediately rinsed with clean water and then dried
- It is inadvisable to use stainless steel pots exclusively to cook foods in salt water (pasta, rice, potatoes, etc.). From time to time, these pots must also be used to cook foods containing fats or vegetables. This helps to prevent damage caused by corrosion
- After cooking foods in salt water, rinse the tanks with fresh water since salt water residues from cooking form layers of highly concentrated saline solution that can cause spotting corrosion
- To prevent so-called secondary corrosion, prolonged contact of stainless steel with ferritic steels should be avoided
- Any secondary corrosion spots must be eliminated immediately
- Do not use sharp objects that may scratch stainless steel parts and consequently give rise to deterioration